

USB Type-C PD3.2

Fast charging protocol intelligent management chip

Product Features

- Be compatible with various of USB Type-A port Fast charge protocol, can intelligently identify the protocol of mobile phone, including: (BC1.2), (Apple2.4A), (QC2.0 Class A), (QC3.0 Class A/B), (FCP), (SCP), (AFC), (low voltage direct charge), etc.
- Be compatible with various USB Type-C protocols, including Type-C protocol, Type-C PD2.0, Type-C PD3.0, Type-C PD3.2, QC4.0 protocol.
- The chip has passed the USB Association PD3.0 certification, TID:
- The maximum output current is optional
- D_{\pm} BV is 15V
- CC BV is 27V
- Constant voltage and constant current function (optional)
- Adjustable voltage accuracy 20mV/step
- Voltage regulation range of the VBUS is 3~20V
- Working voltage 3~21V
- Supports current compensation, 100mV/A
- Pin setting refer to Type-C PD PDO
- Customization refer to Type-C PD PDO
- Integrate over temperature/over current/over voltage/undervoltage/discharge functions
- Package: QFN4X4-16L

Application field

- Charger
- USB panel
- USB HUB
- Car charger
- Other USB Type-A/C power output devices

V0.7(2024.09)

Product Overview

FS8612C belongs to FASTSOC FSFC series, the chip selectively compatible with the mainstream charging protocols. The chip intelligently identifies the type of Mobile and selects the most appropriate protocol for the mobile needs.

The D_{\pm} and CC Break down voltage of the chip are higher than 15V and 27V, with high reliability. At the same time, FS8612C have over temperature, over current, over voltage, under voltage, discharge and other protection functions.

FS8612C has a minimum power supply of 3V and a maximum power supply of 21V, which can adapt to the output voltage of various fast charging protocols.

FS8612C gives the user the choice of common Type-C PDO settings. Users can select different system settings by configuring the external resistor of the FUNC pin according to the application needs

FS8612C provides a rich PDO configuration for users.

FS8612C provides QFN4X4-16L package type, very convenient for you to arrange reasonable scheme.

Order information

Part No	Package	Pcs/Reel
FS8612C-XYZQ6	QFN4X4-16L	4000

comment: XYZ is selected according to specific function, refer to "device selection"

Chip packaging and pin definition

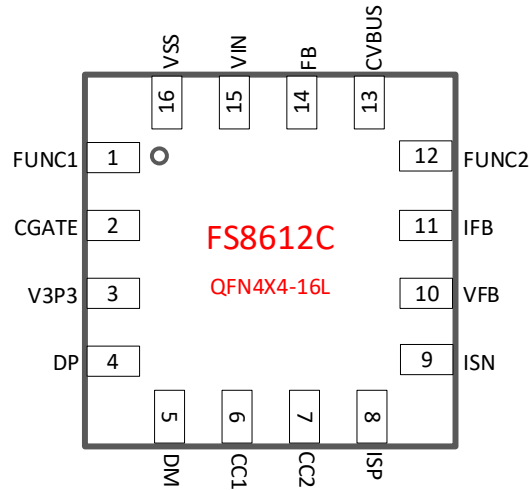

Pic 1. Pin definition

Table 1. FS8612C-XYZ Pin function description

QFN	Name of the pin	Description
1	FUNC1	Connect an external resistor, Set the PDO of Type -C
2	CGATE	Control the Voltage of CVBUS in Type-C port, control PMOSFET
3	V3P3	Internal LDO, connect external 1uF capacitor
4	DP	Connect the USB type-C DP pin
5	DM	Connect the USB Type-C DM pin
6	CC1	Connect the USB Type-C CC1 pin
7	CC2	Connect the USB Type-C CC2 pin
8	ISP	Current sampling positive pole
9	ISN	Current sampling negative pole
10	VFB	Grounded through 100R resistor
11	IFB	No connection
12	FUNC2	Connect an external resistor, Set the PDO of Type -C
13	CVBUS	Connect to the VBUS pin of Type-C port
14	FB	As FB function, connect 431/432 etc.
15	VIN	Power Input, connected to the output of a power supply system
16	VSS	Chip ground, connected to the system ground
EP	NA	No function, can be none-connected



Extreme operating range

Table 2. Maximum operating range

Parameter	value
VIN, CVBUS, CGATE, FB	-0.3V~27V
CC1, CC2	-0.3V~27V
DP, DM	-0.3V~15V
ISP, ISN	-0.3V~5.5V
ESD (HBM)	±2KV

The maximum operating range listed in the table above, if the limit is exceeded, the chip may be permanently damaged. Users should try to avoid it.

Normal operating range

Table 3. Normal operating range

Parameter	value
VIN	3V~21V
D± CC1 CC2	0V~3.3V
FUNC, FB	0V~3.3V
Operating temperature range	-40°~85°
Working current	<1mA

Device Configuration

FSFC series IC have plenty of configuration options that include several broad categories: protocol type, declared power and voltage, list as following.

Protocol type

The FSFC series is compatible with various protocols of port A and port C. FASTSOC will provide commonly used chip types for users to choose, but users can still customize the type of agreement, Please contact the sales for details.

Table 4. List of compatible protocol types

Port A protocol								Port C protocol				
Apple 2.4A	BC1.2	QC2.0	QC3.0	FCP	AFC	SCP	Low voltage charging	TypeC	PD2	PD3	PD3.2	QC4



Declared power and voltage

The IC offers a variety of power and voltage options for customers.

The IC offers a variety of power and voltage options for customers.

The first type related to C port protocol, such as QC4.0 and PD etc., divided into power and maximum Voltage.

PD power supports to 18W、24W、60W、87W etc.

PD maximum voltage supports to 9V、12V、15V、20V etc.

In addition, FSFC series provides a special FUNC Pin, the user can set part of the PDO by connecting external resistor to the ground, improve the application flexibility of the chip. The Settings of the FUNC Pin always have the highest priority.

For the CC threshold, Fixed PDO is set to 115% of the broadcast current and PPS PDO is set to 105% of the request current.

Protection function

If OCP protection is enabled, the OCP threshold is 120% of the maximum current capacity.

The OVP guard point is 125% of the set voltage.

For FIXPDO, the UVP is set to 60% of the set voltage, and for PPS PDO, the UVP is set to Fixed 3.1V.

OTP is set to 140 ° C to 100 ° C for hysteresis.

The UVP, OVP, OCP, and OTP switches are enabled by default.

Device selection

According to the PDO setting corresponding to FUNC Pin position, FS8612C is divided into three series, which are:

- Low power mode: FS8612CL
- High power mode: FS8612CH
- Power reduction mode: FS8612CP

The identification mode of the FS8612C series is FS8612CL/H/P-XYZ. For example, the official name: FS8612CL-20W12V-C, the choice of X depends on the declared voltage and power type. It is not listed completely in the data sheet.

For example, 20W9V indicates that the PDO is 20W and the maximum voltage is 9V, including 5V/3A and 9V/2.22A

Y is usually used for type C chip protocols

Z is for other model.



Pin definition and instructions

VIN

The VIN supplies power to the chip, supporting a minimum of 3V and a maximum of 21V.

The VIN can be directly connected to the output of the power system.

V3P3

Connect external 1uF capacitor.

FUNC1/FUNC2

You can choose different PDOs and system features, as shown in the following table. If the external resistance is 100 KΩ, the resistance with 1% accuracy is recommended.

Table 10. F8612C FUNC Pin function

FUNC2	FUNC1	PDO0	PDO1	PDO2	PDO3	PDO4	Remark
No Connection	No Connection	customization					
Ground	No Connection	5V3A	9V2.22A				20W
Ground	Resistor	5V3A	9V2.22A	12V1.67A			20W
Resistor	No Connection	5V3A	9V2A	12V1.5A	3.3~5.9V3A	3.3~11V1.5A	18W
Resistor	Resistor	5V3A	9V2.77A	12V2.1A	3.3~5.9V3A	3.3~11V2.45A	25W
Resistor	Ground	5V3A	9V2A				18W
No Connection	Resistor	5V3A	9V2.77A	3.3~5.9V3A	3.3~11V2.25A		25W
No Connection	Ground	5V3A	9V3A	12V2.25A	3.3~5.9V3A	3.3~11V2.45A	27W
Ground	Ground	Shielding fast charge, 5V/3A					

For the configuration of FUNC pin of FS8612C H/P, please consult the original manufacturer.

DP and DM

DP and DM breaking down voltage (BV) is greater than 15V, which improves the stability of system insertion and removal.

CC1 and CC2

CC1 and CC2 Connect to CC1 and CC2 in the Type-C port. CC1 and CC2 BV is above 27V, which improves the stability of system insertion and removal.



ISP and ISN

ISP and ISN are used for current sampling and are connected to 5 mΩ sampling resistors.

A sampling network is usually used in conjunction with the sampling resistance. Refer to the application example for the network structure.

The GND on the type-C port needs to be connected to the ISP, but cannot be connected to the system Ground directly.

ISP and ISN in PCB design will affect the accuracy of current sampling value, should be connected to the sampling network, ISN connected to the sampling resistor end, cannot be directly connected to the system ground.

VFB/IFB

VFB ground through 100R resistance.

IFB no connection

FB

As a FB application, the FB is connected to the power supply system and used to control the VBUS voltage of the USB. After the mobile phone and FSFC negotiate the protocol through D±/CC and the required voltage, FSFC initiates voltage regulation through FB. The Voltage regulating accuracy of FB is 20mV, and the voltage regulating speed is 200mV / 500us. Assume that FB is connected with an external resistor R1 to VBUS and an external resistor R2 to ground. The usual calculation formula is as follows,

$$R_2 = \frac{R_1 V_{FB}}{V_{VBUS} - V_{FB}}$$

For instance,

V_{VBUS} take 5V

V_{FB} can be found in the manual of the power IC, for example, take 0.8V

The typical value of R₁ is 100 KΩ. The precision must meet system requirements, for example, 1%

So we can figure out R₂.

CGATE

External PMOS is connected to control the channel switch between VIN and CVBUS.

It's low-cost applications, PMOS optional.

CVBUS

CVBUS Connects to the VBUS pin of port Type-C. CVBUS has built-in discharge circuit loop.

Application example

A typical application of FS8612C is shown in the figure. The chip power supply is taken from AC/DC output.

FB feedback application

VFB ground

FUNC1/2 connect external resistor for functional setting.

FB Connects to the FB of DC/DC or 431/432. CGATE connects to external PMOS control VBUS output (optional).

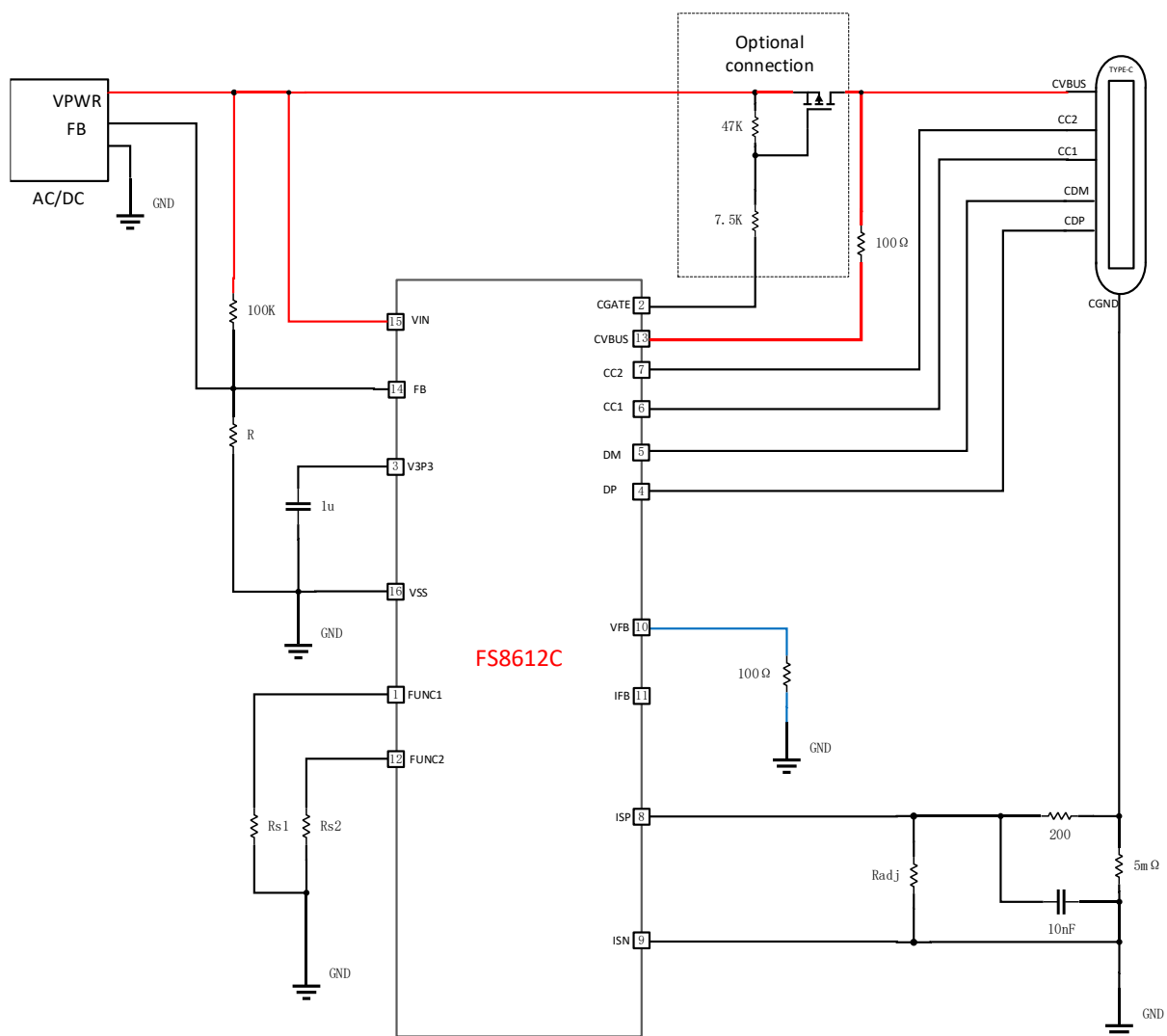
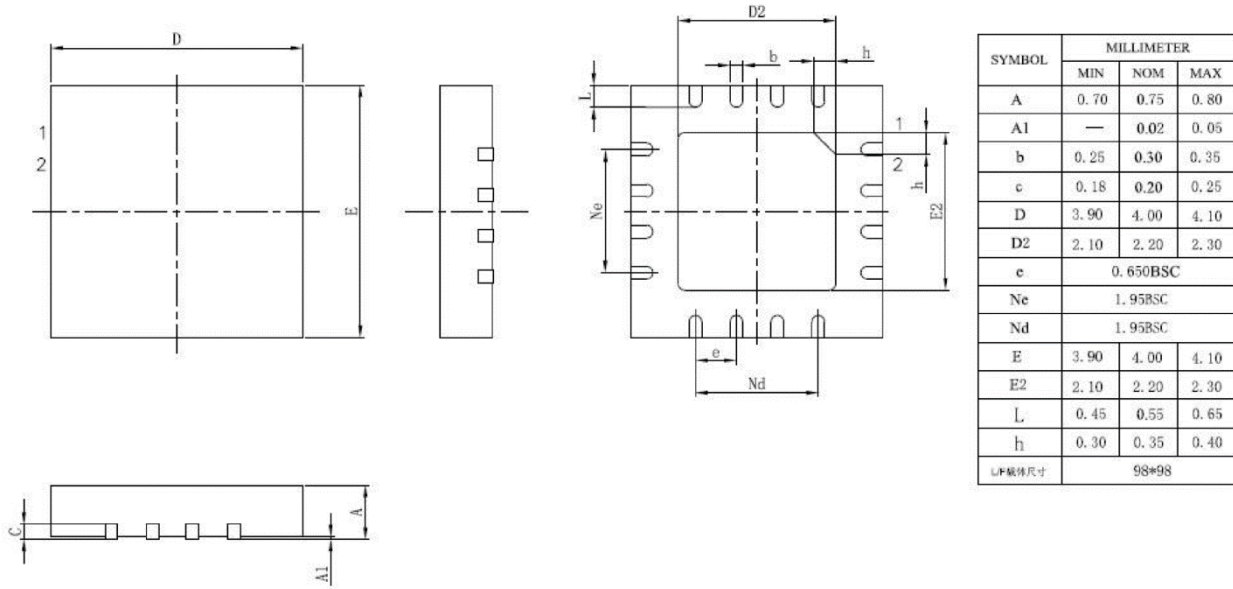

Figure 3. Application diagram of FB



Package outline drawing

QFN4X4-16L



Screen printing instructions

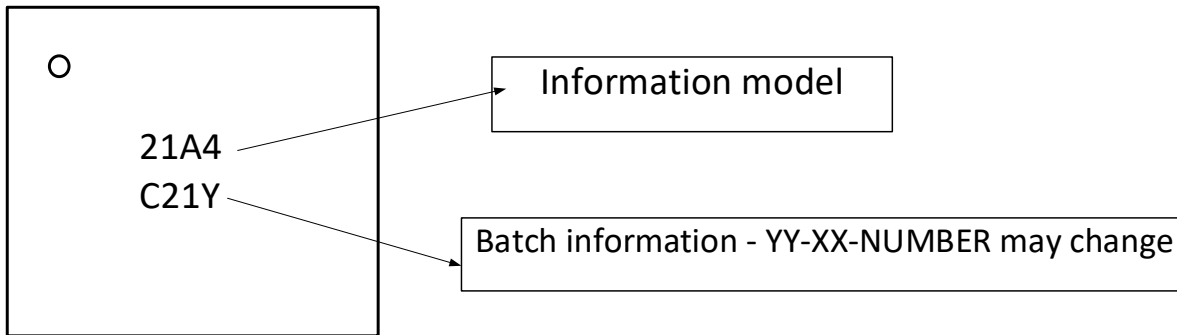



Company information and statement

HQ

E2-503, China Internet of Things International Innovation Park, No. 200, Linghu Avenue, Xinwu District, Wuxi City

Website: www.fastsoc.com

Wechat public Account.: fastsoc

Sales and technical support

Contact: Ms. Ge

Mobilephone: 1895-248-8621

E-mail: gejing@fastsoc.com

Statement

Wuxi FASTSOC Microelectronics co., Ltd. reserves the right to modify the product and the product data manual at any time. All information in this document, including product functions, performance, and company information, may be modified without informing users. The functional and performance indicators described in this article were tested in a laboratory environment and there is no guarantee that the same data will be available on customer products. The information herein does not imply, indicate, support, prove or imply in any form that the Product can be used for any application that infringes the intellectual property rights of any third party. The information herein is only for guidance in the use of the chip and does not authorize users to use the intellectual property rights of Our company or any other company.

Our products are not designed for extreme conditions and life support systems. If the user chooses to use it on these occasions, it is at the user's own risk without our confirmation and permission.

Wuxi FASTSOC Microelectronics Co., Ltd. and its registered and used trademarks, logos, all kinds of intellectual property rights belong to Wuxi FASTSOC Microelectronics Co., LTD. All other trademarks, logos, designs, and material numbers used herein are the property of their respective owners