

SB Type-C PD3.0 **Dual-port** Fast charging protocol intelligent management chip

Product Features

- Be compatible with various of USB Type-A port Fast charge protocol, can intelligently identify the protocol of mobile phone, including: (BC1.2), (Apple2.4A), (QC2.0 Class A), (QC3.0 Class A/B), (FCP), (SCP), (AFC), (low voltage direct charge), etc.
- Be compatible with various USB Type-C protocols, including Type-C protocol, Type-C PD2.0, Type-C PD3.0, Type-C PD3.0 PPS, QC4.0 protocol.
- PDO can be customized
- Support A+C dual port operation, the voltage automatically reverts to 5V When dual port connecting at the same time
- The maximum output current is optional
- D_{\pm} BV is 15V
- CC BV is 27V
- 5m Ω sampling resistor
- Constant voltage and constant current function (optional)
- Adjustable voltage accuracy 20mV/step
- VBUS voltage range 3~20V
- Working voltage 3~21V
- Supports current compensation, 1A/100mV
- Pin setting refer to Type-C PD PDO
- Customization refer to Type-C PD PDO
- Integrate over temperature/over current/over voltage/undervoltage/discharge functions
- Package: QFN3X3-20L

Application field

- Charger
- USB panel
- USB HUB
- Car charger
- Other USB Type-A/C power output devices

V0.6 (202310)

Product Overview

FS8628 belongs to FASTSOC FSFC series, the chip selectively compatible with the mainstream charging protocols. The chip intelligently identifies the type of Mobile and selects the most appropriate protocol for the mobile needs.

The chip has constant voltage and constant current functions.

The D_{\pm} and CC Break down voltage of the chip are higher than 15V and 27V, with high reliability. At the same time, FS8628 have over temperature, over current, over voltage, under voltage, discharge and other protection functions.

FS8628 has a minimum power supply of 3V and a maximum power supply of 21V, which can adapt to the output voltage of various fast charging protocols.

FS8628 gives the user the choice of common Type-C PDO Settings. Users can select different system Settings by configuring the external resistor of the FUNC pin according to the application needs.

FS8628 provides a rich PDO configuration for users.

FS8628 provides QFN3X3-20L package type, very convenient for you to arrange reasonable scheme.

Order information

Part No	Package	Pcs/Reel
FS8628- <u>XYZ</u>	QFN3X3-20L	4000

comment: XYZ is selected according to specific function, refer to "device selection"

Chip packaging and pin definition

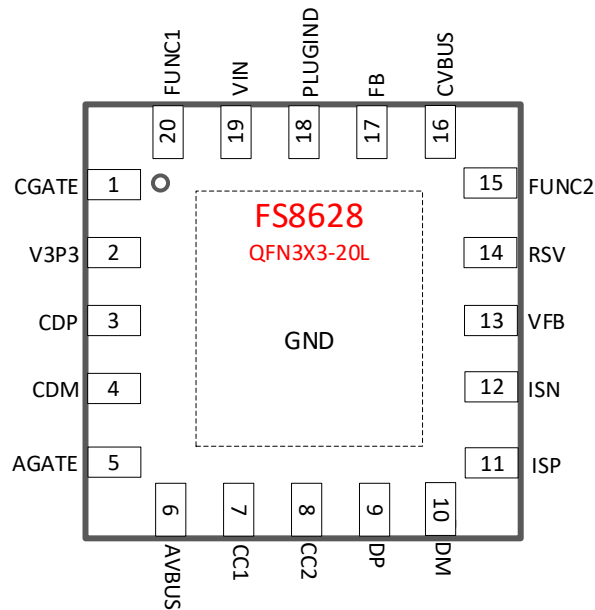

Pic 1. Pin definition

Table 1. FS8628-XYZ Pin function description

QFN	Name of the pin	Description
1	CGATE	Control the Voltage of CVBUS in Type-C port, Control PMOSFET
2	V3P3	Internal LDO, connect external 1uF capacitor
3	CDP	Connect the USB Type-C DP pin
4	CDM	Connect the USB Type-C DM pin
5	AGATE	Control the Voltage of AVBUS in Type-A port, Control PMOSFET
6	AVBUS	Connect to the VBUS pin of Type-A port
7	CC1	Connect the USB Type-C CC1 pin
8	CC2	Connect the USB Type-C CC2 pin
9	DP	Connect the USB type-A DP pin
10	DM	Connect the USB Type-A DM pin
11	ISP	Current sampling positive pole
12	ISN	Current sampling negative pole
13	VFB	grounded through 100R resistor
14	RSV	Reserved
15	FUNC2	Connect an external resistor, Set the PDO of Type -C
16	CVBUS	Connect to the VBUS pin of Type-C



17	FB	Voltage regulation feedback pin
18	PLUGIND	Insert instruction
19	VIN	Power Input, connected to the output of a power supply system
20	FUNC1	Connect an external resistor, Set the PDO of Type -C
EP	GND	Ground

Extreme operating range

Table 2. Maximum working range

Parameter	value
VIN, CVBUS, CGATE, FB	-0.3V~27V
CC1, CC2	-0.3V~27V
DP, DM	-0.3V~15V
ISP, ISN	-0.3V~5.5V
ESD (HBM)	±2KV

The maximum operating range listed in the table above, if the limit is exceeded, the chip may be permanently damaged. Users should try to avoid it.

Normal operating range

Table 3. Normal operating range

Parameter	value
VIN	3V~21V
D± CC1 CC2	0V~3.3V
FUNC, FB	0V~3.3V
Operating temperature range	-40°~85°
Working current	<1mA

Device Configuration

FSFC series IC have plenty of configuration options that include several broad categories: protocol type, declared power and voltage, and system current capability. List as following.



Protocol type

The FSFC series is compatible with various protocols of port A and port C. FASTSOC will provide commonly used chip types for users to choose, but users can still customize the type of agreement, please contact the sales for details.

Table 4. List of compatible protocol types

Port A protocol								Port C protocol				
Apple 2.4A	BC1.2	QC2.0	QC3.0	FCP	AFC	SCP	Low voltage charging	Type-C	PD2	PD3	PPS	QC4

Declared power and voltage

The IC offers a variety of power and voltage options for customers.

The first type related to C port protocol, such as QC4.0 and PD etc, divided into power and maximum Voltage.

PD power supports to 18W、24W、60W、87W etc;

PD maximum voltage supports to 9V、12V、14.5V、15V、20V etc;

In addition, FSFC series provides a special FUNC Pin, the user can set part of the PDO by external resistor to the ground, improve the application flexibility of the chip. The ettings made by the FUNC Pin always have the highest priority.

For the CC threshold, Fixed PDO is set to 115% of the broadcast current and PPS PDO is set to 105% of the request current.

Protection function

If OCP protection is enabled, the OCP threshold is 120% of the maximum current capacity.

The OVP guard point is 125% of the set voltage.

For Fixed PDO, the UVP is set to 60% of the set voltage, and for PPS PDO, the UVP is set to Fixed 3.1V.

OTP is set to 140 ° C to 100 ° C for hysteresis.

Device selection

According to the PDO setting corresponding to FUNC Pin position, FS8628 is divided into three series, which are:

- Low power mode (12V and below output) : FS8628L
- High power mode (above 12V output) : FS8628H
- Power reduction mode (use as chip sets) : FS8628

The identification mode of the FS8628 series is FS8628L/H/P-XYZ. For example, the official name: FS8628L-20W12V-C, the choice of X depends on the declared voltage and power type. It is not listed completely in the data sheet.

For example, 20W9V indicates that the PDO is 20W and the maximum voltage is 9V, including 5V/3A and 9V/2.22A

Y is usually used for type C chip protocols

Z is for other model.



Pin definition and instructions

VIN

The VIN supplies power to the chip, supporting a minimum of 3V and a maximum of 21V.

The VIN can be directly connected to the output of the power system.

V3P3

Connect external 1uF capacitor

FUNC1/FUNC2

You can choose different PDOs and system features, as shown in the following table. If the external resistance is 100 KΩ, the resistance with 1% accuracy is recommended.

For FS8628L, the FUNC function is set as follows:

Table 10. FUNC Pin function

FUNC2	FUNC1	PDO0	PDO1	PDO2	PDO3	PDO4	Remark
No Connection	No Connection	OTP setting					
Ground	No Connection	5V3A	9V2.22A				20W
Ground	Resistor	5V3A	9V2.22A	12V1.67A			20W
Resistor	No Connection	5V3A	9V2A	12V1.5A	3.3~5.9V3A	3.3~11V1.5A	18W
Resistor	Resistor	5V3A	9V2.77A	12V2.1A	3.3~5.9V3A	3.3~11V2.45A	25W
Resistor	Ground	5V3A	9V2A				18W
No Connection	Resistor	5V3A	9V2.77A	3.3~5.9V3A	3.3~11V2.25A		25W
No Connection	Ground	5V3A	9V3A	12V2.25A	3.3~5.9V3A	3.3~11V2.45A	27W
Ground	Ground	Shielding fast charge, 5V/3A					

For the configuration of FUNC pin of FS8628H/P, please consult the original manufacturer.

DP and DM

DP and DM breaking down voltage(BV) is greater than 15V, which improves the stability of system insertion and removal.

DP/DM Connects to the Type-A port.

CDP and CDM

Both CDP and CDM BV is greater than 15V, which improves the stability of system insertion and removal.

The CDP/CDM connects to the Type-C port.

**CC1 and CC2**

CC1 and CC2 Connect to CC1 and CC2 in the Type-C port. CC1 and CC2 BV is above 27V, which improves the stability of system insertion and removal.

ISP and ISN

ISP and ISN are used for current sampling and are connected to 5 mΩ sampling resistors.

A sampling network is usually used in conjunction with the sampling resistance, refer to the application example for the network structure.

The GND on the type-C port needs to be connected to the ISP, but cannot be connected to the system Ground directly.

ISP and ISN in PCB design will affect the accuracy of current sampling value, should be connected to the sampling network, ISN connected to the sampling resistor end, cannot be directly connected to the system ground.

VFB

Ground through 100R resistance.

FB

As a FB application, the FB is connected to the power supply system and used to control the VBUS voltage of the USB. After the mobile phone and FSFC negotiate the protocol through D±/CC and the required voltage, FSFC initiates voltage regulation through FB. The Voltage regulating accuracy of FB is 20mV, and the voltage regulating speed is 200mV / 500us.

Assume that FB is connected with an external resistor R1 to VBUS and an external resistor R2 to ground. The usual calculation formula is as follows,

$$R_2 = \frac{R_1 V_{FB}}{V_{VBUS} - V_{FB}}$$

For instance,

V_{VBUS} take 5 V

V_{FB} can be found in the manual of the power IC, for example, take 0.8V

The typical value of R_1 is 100 KΩ. The precision must meet system requirements, for example, 1%

So we can figure out R2.

AGATE

Connect external PMOS to control the channel switch between VIN and AVBUS

CGATE

Connect external PMOS to control the channel switch between VIN and CVBUS.

AVBUS

AVBUS connects to the VBUS pin of port Type-A.

CVBUS

CVBUS connects to the VBUS pin of port Type-C. CVBUS has built-in discharge circuit loop.

PLUGIND

Insert indication, OD output.

Application example

A typical application of FS8628 is shown in the figure. The chip power supply is taken from AC/DC output.

FB8628L FB feedback application

FUNC connect external resistor for functional setting.

FB connects to the FB of DC/DC or 431/432.

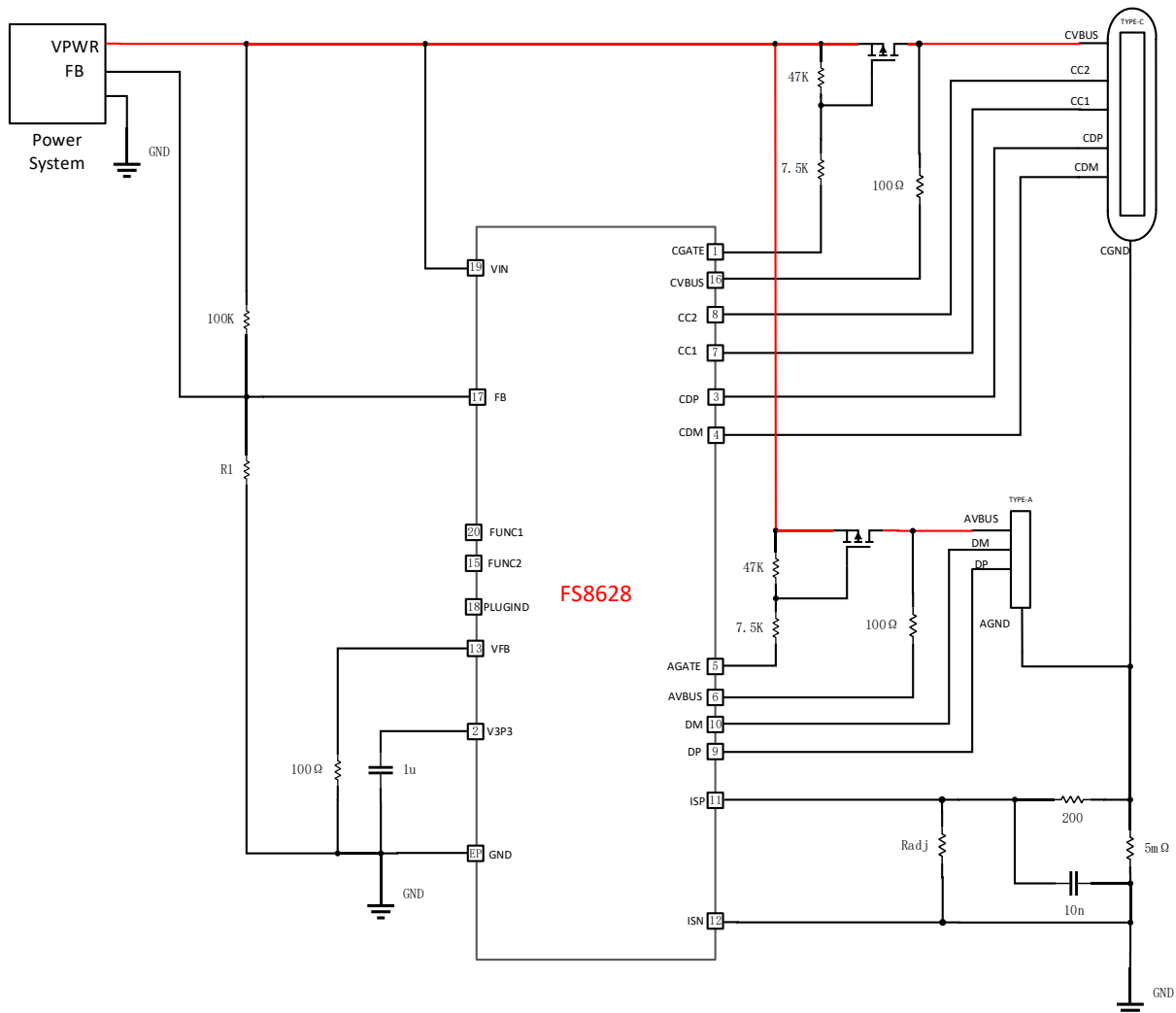

Figure 3. Application diagram of FS8628L FB

FS8628H FB feedback application

VFB Ground

Func1/2 an external resistor is used to set the function.

FB Connects to the FB of DC/DC or 431/432.

For FS8628H or FS8628P, if the PDO or port A voltage contains Settings greater than 12V, customers are advised to add protection circuits for AVBUS and AGATE as follows.

9.1V is recommended for the voltage regulator.

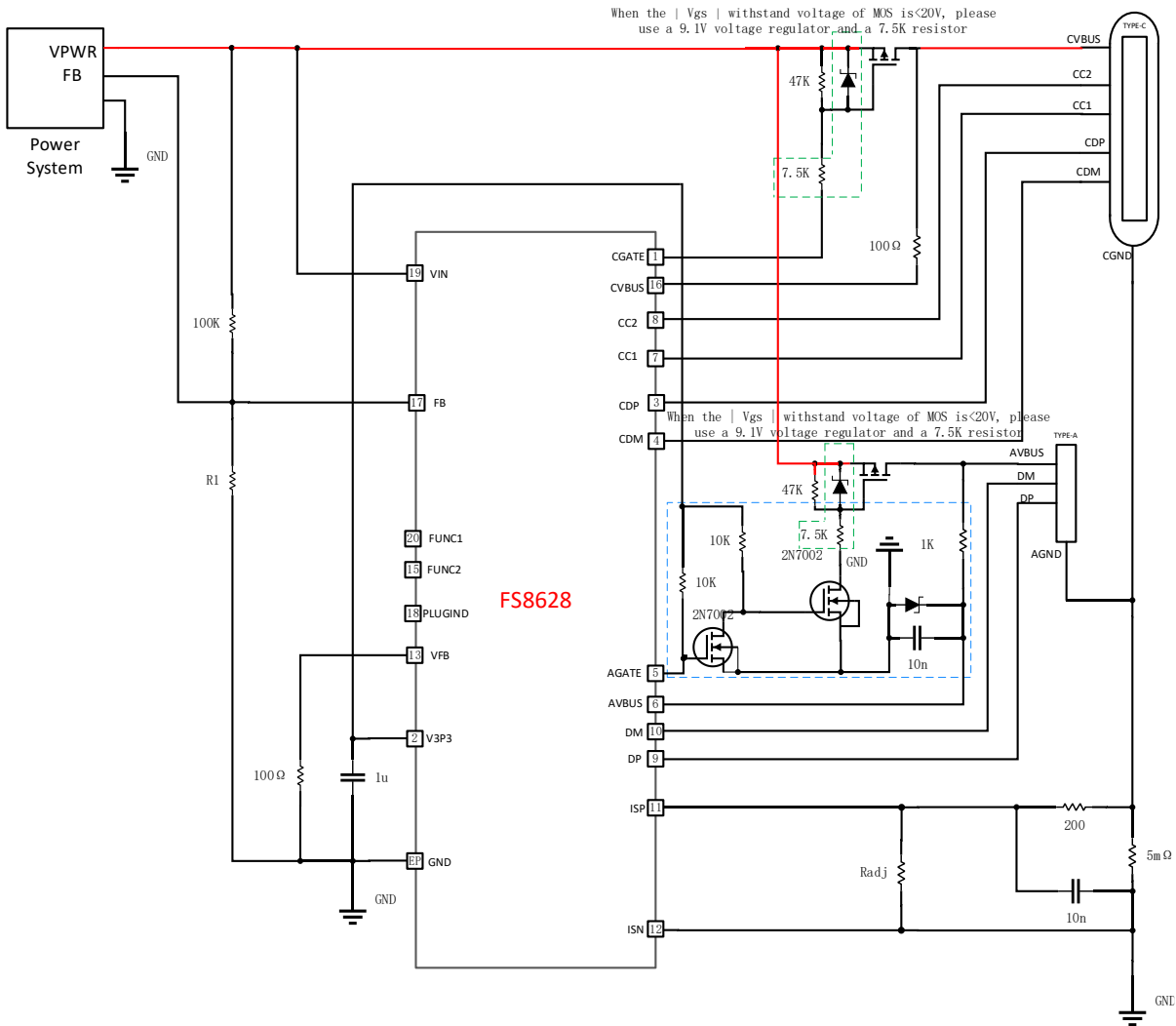
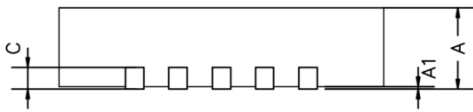
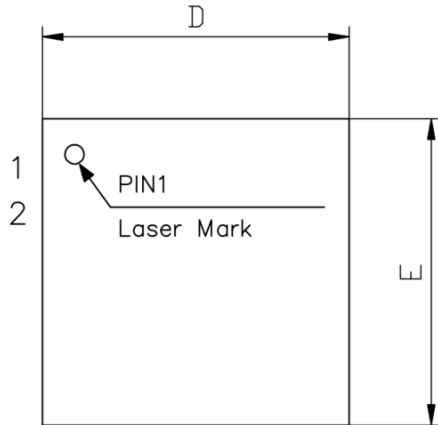

Figure 4. Application diagram of FS8628H FB

Package outline drawing

QFN3X3-20L

QFN20L(0303X0.75-0.40) POD



SYMBOL	MIN	NOM	MAX
A	0.7	0.75	0.8
A1	—	0.02	0.05
b	0.15	0.20	0.25
c	0.18	0.2	0.25
D	2.9	3.0	3.1
D2	1.55	1.65	1.75
e	0.4BSC		
Nd/Ne	1.60BSC		
C1/C2	—	0.12	—
E	2.9	3.0	3.1
E2	1.55	1.65	1.75
L	0.35	0.4	0.45
h	0.2	0.25	0.3

NOTES:

1. ALL DIMENSIONS REFER TO JEDEC STANDARD MO-229 (WEED-4/WEED-4)
2. DIMENSION D DOES NOT INCLUDE MOLD FLASH
3. DIMENSION E1 DOES NOT INCLUDE MOLD FLASH
4. FLASH OR PROTRUSION SHALL NOT EXCEED 0.25mm PER SIDE.

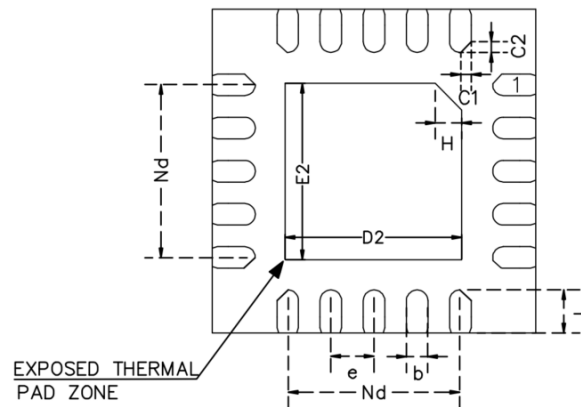

BOTTOM VIEW



Company information and statement

HQ

E2-503, China Internet of Things International Innovation Park, No. 200, Linghu Avenue, Xinwu District, Wuxi City

Website: www.fastsoc.com

Wechat public Account.: fastsoc

Shanghai R&D Center

Room 104, Building 3, No. 1690, Cailun Road, China (Shanghai) Pilot Free Trade Zone

Sales and technical support

Contact: Mr. Gu

Mobilephone: 1895-248-8621

E-mail: gejing@fastsoc.com

Statement

Wuxi FASTSOC Microelectronics co., Ltd. reserves the right to modify the product and the product data manual at any time. All information in this document, including product functions, performance, and company information, may be modified without informing users. The functional and performance indicators described in this article were tested in a laboratory environment and there is no guarantee that the same data will be available on customer products. The information herein does not imply, indicate, support, prove or imply in any form that the Product can be used for any application that infringes the intellectual property rights of any third party. The information herein is only for guidance in the use of the chip and does not authorize users to use the intellectual property rights of our company or any other company.

Our products are not designed for extreme conditions and life support systems. If the user chooses to use it on these occasions, it is at the user's own risk without our confirmation and permission.

Wuxi FASTSOC Microelectronics Co., Ltd. and its registered and used trademarks, logos, all kinds of intellectual property rights belong to Wuxi FASTSOC Microelectronics Co., Ltd. All other trademarks, logos, designs, and material numbers used herein are the property of their respective owners.